



# Master Series Gas XPress Grill

Item: \_\_\_\_\_  
 Quantity: \_\_\_\_\_  
 Project: \_\_\_\_\_  
 Approval: \_\_\_\_\_  
 Date: \_\_\_\_\_

Master Series Gas XPress Grill

Models:

XPG12

XPG12CE



**Model XPG12**  
Shown with straight grease cans



### Standard Features:

- Programmable control for each cooking lane precisely controls:
  - Automatic lifting and lowering of upper platen
  - Cooking gap and time
  - EasyTouch™ screen design is simple and intuitive with Press and Go interface
- Advanced temperature control, smart anticipation versus on-off
  - Eliminates temperature overshoot and undershoot
  - Increases temperature uniformity with five independently controlled heat zones -- three on plate and two on platen
- Recipes are programmed by setting grill temperature, platen temperature, cooking gap up to 2 inches (5 cm) and cook time

- USB interface to update menus
- User interface provides advanced diagnostics and error logging for ease of service and increased first-time fix
- Stainless steel front, top and sides
- Towel bar with bun pan lip
- Stainless steel dual side grease collectors
- Swivel casters (4) with front brakes
- IPX4 water resistant rating
- Two-year limited parts and labor (USA & Canada)

### Optional Features:

- Grease cans are available with
  - straight sides for minimum space
  - flared sides to hold optional tool holders
- Optional tool holders
  - 4-inch spatula
  - 6-inch scraper
  - 7-inch wiper

### Specifications:

The XPress Grill's upper and lower grill plates cook both sides simultaneously, reducing cook times by up to 50%. Upper grill plate is automatically raised and lowered by a lift system powered by a quiet actuator.

Lower griddle plate made of 3/4" (19mm) thick carbon steel, machine ground and highly polished.

Lower grill plate heated by one electric heating element and two gas burners.

Upper platen heated by nickel plated cast aluminum electric heating elements.

Electric top heater provided with replaceable quick release Teflon sheets. Available in three phase power for Delta or Wye electrical systems.

Voltage sensing and power management automatically adjusts power to electrical system voltage.

Available with CSA approvals for natural or propane gas.

Available with CE approvals for G20, G25, and G31 gas.

All have NSF approval.

Installation with zero clearance against non-combustible surfaces.

**NOTE:** Grills supplied with casters and installed with flexible gas hose must be installed with an approved restraining device.



**Garland Commercial Ranges Ltd.**  
 1177 Kamato Road,  
 Mississauga, Ontario  
 L4W 1X4 CANADA

**General Inquires 1-905-624-0260**  
**USA Sales, Parts and Service 1-800-424-2411**  
**Canadian Sales 1-888-442-7526**  
**Canada or USA Parts/Service 1-800-427-6668**



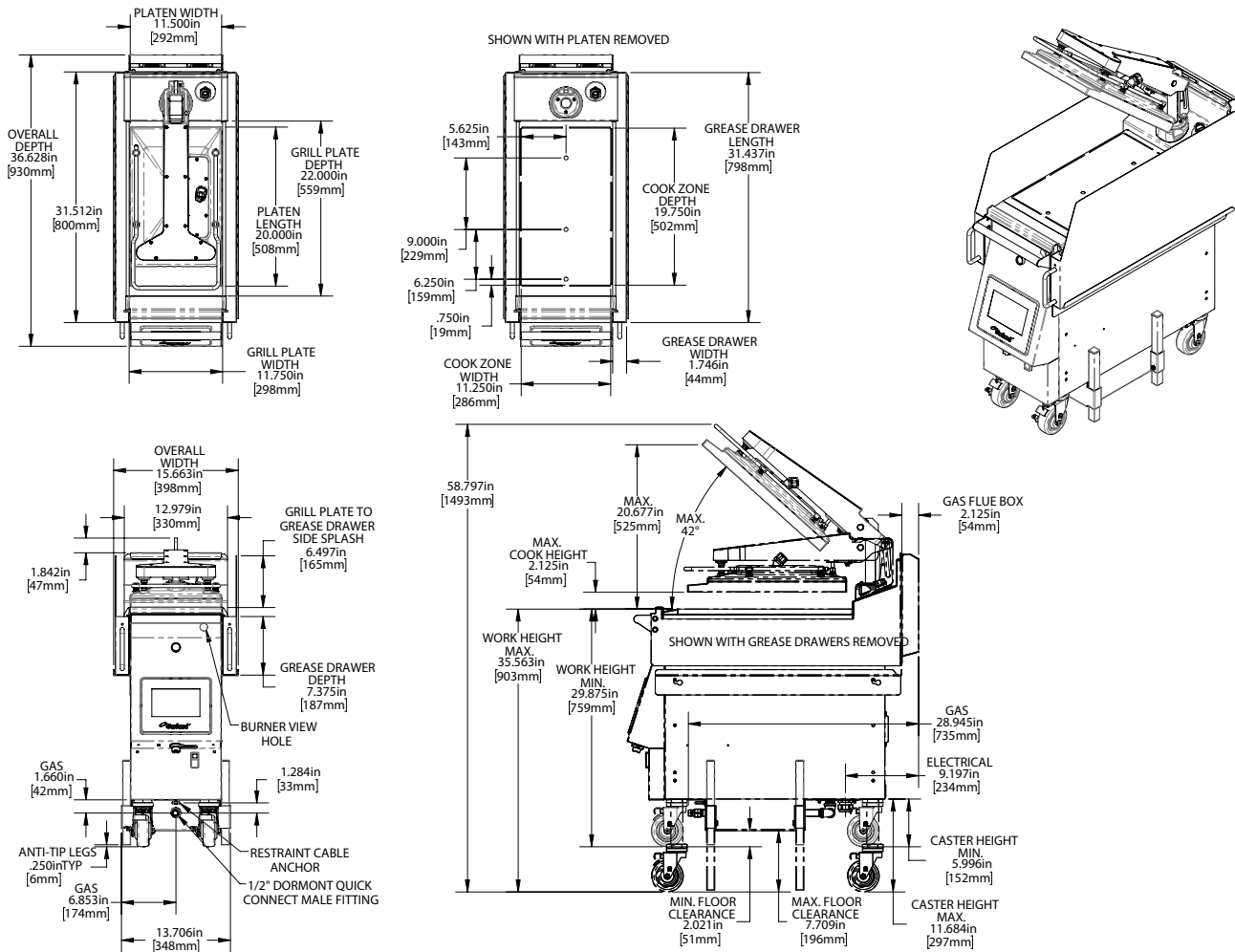

**Gas Input Rating:**

20,000 BTU

**Supply Pressure:**

G20 natural gas: 20mbar; G25 natural gas: 25mbar;  
G31 propane gas: 30/37/50mbar

Natural gas 7" WC; Propane 11" WC

**Electrical Input Specification - DELTA**

XPG12 CSA MODELS - DELTA					
MODEL	Volts 3 Ph 50/60 Hz	Total Current (A)			Power (kW)
		L1	L2	L3	
1 Platen	200V	14.4	16.8	4.7	3.5
	208V	14.0	16.5	4.8	3.5
	220V	12.6	15.0	4.7	3.4
	230V	11.8	14.2	4.7	3.4
	240V	11.8	14.1	4.7	3.4

**Electrical Input Specification - WYE**

XPG12 CE MODELS - WYE					
MODEL	Volts 3 Ph 50/60 Hz	Total Current (A)			Power (kW)
		L1	L2	L3	
1 Platen	220V/380V	12.6	4.7	0.0	3.4
	230V/400V	11.8	4.7	0.0	3.4
	240V/415V	11.8	4.7	0.0	3.4

Form# XPG12 (07/06/16)